



# Wiring Diagrams

50/60 Hz

## DIAGRAM INDEX

| MODEL NO.<br>30GT | VOLTAGE         |                    | FIG. NO.                    |                                    |                           |                               |         |                                      |                 | LABEL NO.<br>(FIG. NO.)<br>30GT |                |
|-------------------|-----------------|--------------------|-----------------------------|------------------------------------|---------------------------|-------------------------------|---------|--------------------------------------|-----------------|---------------------------------|----------------|
|                   | Main<br>V-Ph-Hz | Control<br>V-Ph-Hz | Compr<br>Power<br>Schematic | Component<br>Arrangement,<br>Power | Fan<br>Power<br>Schematic | Control<br>Power<br>Schematic |         | Component<br>Arrangement,<br>Control | Field<br>Wiring |                                 |                |
|                   |                 |                    |                             |                                    |                           | 24 v                          | 115-230 |                                      |                 |                                 |                |
| 225               | 200             | 380-3-60           | 220-1-60                    | 1                                  |                           |                               |         |                                      |                 |                                 | 508049A<br>(1) |
|                   | 600             | 460-3-60           | 115-1-60                    | 2                                  |                           |                               |         |                                      |                 |                                 | 508048A<br>(2) |
|                   | 100             | 575-3-60           | 115-1-60                    | 2                                  | 3                         | 4                             | 6       | 7                                    | 8               | 9                               | 510073B<br>(3) |
|                   | 300             | 346-3-50           | 200/220-1-50                | 1                                  |                           |                               |         |                                      |                 |                                 | 508051A<br>(4) |
|                   | 900             | 380/415-3-50       | 230-1-50                    | 2                                  |                           |                               |         |                                      |                 |                                 | 508052A<br>(5) |
| 250               | 200             | 380-3-60           | 220-1-60                    | 1                                  |                           |                               |         |                                      |                 |                                 | 510062<br>(6)  |
|                   | 600             | 460-3-60           | 115-1-60                    | 2                                  |                           |                               |         |                                      |                 |                                 | 510061C<br>(7) |
|                   | 100             | 575-3-60           | 115-1-60                    | 2                                  | 3                         | 5                             | 6       | 7                                    | 8               | 9                               | 510063A<br>(8) |
|                   | 300             | 346-3-50           | 200/220-1-50                | 1                                  |                           |                               |         |                                      |                 |                                 | 510082<br>(9)  |
|                   | 900             | 380/415-3-50       | 230-1-50                    | 2                                  |                           |                               |         |                                      |                 |                                 |                |
| 280               | 200             | 380-3-60           | 220-1-60                    | 1                                  |                           |                               |         |                                      |                 |                                 |                |
|                   | 600             | 460-3-60           | 115-1-60                    | 2                                  |                           |                               |         |                                      |                 |                                 |                |
|                   | 100             | 575-3-60           | 115-1-60                    | 2                                  | 3                         | 5                             | 6       | 7                                    | 8               | 9                               |                |
|                   | 300             | 346-3-50           | 200/220-1-50                | 1                                  |                           |                               |         |                                      |                 |                                 |                |
|                   | 900             | 380/415-3-50       | 230-1-60                    | 2                                  |                           |                               |         |                                      |                 |                                 |                |

FIELD-INSTALLED ACCESSORIES:

|  |            |
|--|------------|
| Demand Limit Control Module              | Fig. 10,11 |
| Temporary Reset Board                    | 12         |
| Reset Thermistor                         | 13         |
| Space/Outside Air Thermistor Connections | 14         |
| Remote On/Off Control                    | 15         |
| External Interlocks and Alarm            | 16         |

*Italics denote 60-Hz export units (not for sale in U.S.A.).*

### SAFETY CONSIDERATIONS

Installing, starting-up and servicing air conditioning equipment can be hazardous due to system pressures, electrical components and equipment location (roofs, elevated structures, etc.).

Only trained, qualified installers and service mechanics should install, start-up and service this equipment. Untrained personnel can perform basic maintenance functions such as cleaning coils. All other operations should be performed by trained service personnel. When working on the equipment, observe precautions in the literature and on tags, stickers and labels attached to the equipment. Follow all safety codes. Wear safety glasses and work gloves.

### NOTES (For Fig. 1 - 9)

1. Fan motors thermally protected. Three-phase motors protected against primary single-phasing conditions.
2. Replacement of original wires must be with 105 C wire or its equivalent.
3. Numbers on the right side of label diagrams indicate the line location of applicable contacts. An underlined

number signifies normally closed contacts. A plain number denotes normally open contacts. Line numbers are shown on the left side of the diagrams.

4. Factory wiring is in accordance with National Electrical Code (NEC). Field modifications or additions must be in compliance with all applicable codes.
5. Wiring for main field power supply must be rated 75 C minimum. Use copper, copper clad aluminum or aluminum conductors for all units except use copper conductors only for: 346-v units, 30GT250 380/415-v and 380-v units, and 30GT280 380-v and 460-v part winding start units. Maximum incoming wire size for each terminal block is 500 MCM.
6. Power for control circuit should be supplied from a separate source through a field-supplied disconnect with 30-amp maximum protection for 115-v control circuits and 15-amp maximum protection for 230-v control circuit. Connect control circuit power to terminals 1 and 2 of TB4. Connect neutral side of supply to terminal 2 of TB4. Control circuit conductors for all units must be copper only.

7. Terminals 7 and 8 of TB5 are for field connection of external interlock devices. Remove jumper between terminals 7 and 8 of TB5 when CWP interlocks are used.
8. Terminals 1 and 2 on TB5 are for field remote alarm connections. Electrical rating for field remote alarm is 115-v 60 Hz/230-v 50 Hz and 380-v-3-60. Maximum load is 75-va sealed, 360-va, inrush. Remove resistor across terminals 1 and 2 on TB5 when using remote alarm.
9. For part winding start only, time delay relays are wired between terminals on compressor contactors. Center terminals of Time Delay Relay are then jumpered.
10. Terminals 9 and 10 of TB7 are for field connection for remote on-off control. The contacts must be rated for dry circuit application capable of reliably switching a 5 vdc, .5 ma load. Remove jumper between 9 and 10 of TB7 if remote on-off is installed.

## OPERATION

**IMPORTANT:** Before initial start-up and before re-starting unit after a prolonged shutdown, compressor crankcase heater should be energized for 24 hours.

## SEQUENCE OF OPERATION

During unit off cycle, crankcase heaters are energized. If ambient temperature is below 36 F (2 C), cooler heaters and a microprocessor board heater are also energized.

When control ON-OFF switch is turned to ON, control first goes through a 2-minute initialization period, during which the display continuously shows **20**. Ninety (90) seconds after **20** leaves display, control begins to bring on compressors. Rate at which compressors are started depends on leaving chilled water temperature and rate of change of leaving water temperature. An automatic lead/lag feature in control system determines by random selection either circuit A or circuit B to start first. At first call for cooling, microprocessor starts first compressor, de-energizes crankcase heater and starts 3 condenser fans (2 for 30GT225).

The electronic expansion valve (EXV) remains closed for 10 seconds to purge cooler and suction line of any liquid refrigerant that may have migrated to these areas during off period. After 10 seconds, expansion valve starts to open. As more cooling is required, control brings on additional stages of capacity. Loading sequence for compressors is shown in Installation Instructions, Capacity Control Steps table.

Microprocessor determines how rapidly capacity stages are added or subtracted, based on deviation from leaving chilled water temperature set point and rate of change of leaving water temperature. If water temperature is very warm and pull-down option is being used, microprocessor limits rate of temperature drop of leaving water to 1°F (0.56 C) per minute to avoid high peak kW charges. If the capacity is being limited by pull-down, the control display shows a

**24** when the display button is pressed.

When the capacity is satisfied and a refrigerant circuit is to be shut down, the microprocessor closes the EXV. The compressor continues to run for 10 seconds to purge the cooler and suction line of liquid refrigerant, then stops.

If demand limit option is being used, control limits maximum capacity to load shed input value. Refer to Controls and Troubleshooting publication for details. If capacity is

limited by a load shed signal, display shows a **22** when display button is pressed.











If temperature reset is being used, microprocessor adjusts leaving water temperature to obtain greater part-load efficiency. Refer to Controls and Troubleshooting book for details. If leaving water temperature is being reset, display shows a

**21** when the display button is pressed.

Microprocessor also controls electronic expansion valve (EXV) to maintain a superheat of 20 F to 25 F (11 C to 14 C) entering compressor cylinders. This is equivalent to 3 F to 5 F (2 C to 3 C) superheat leaving cooler.

Microprocessor control also cycles condenser fans on and off to maintain an adequate pressure differential across expansion valves. Fans are controlled by position of EXV and saturated condensing temperature thermistors. This allows unit to run at very low condensing temperatures at part load. Thus, chiller has very high part-load EER's.

## LEGEND (For Fig. 1 to 9)

|              |   |                              |  |   |   |
|--------------|---|------------------------------|--|---|---|
| <b>A</b>     | — | Alarm                        | <b>R</b>   | — | Red (Light)   |
| <b>ALMR</b>  | — | Alarm Relay                  | <b>RB</b>  | — | Reset Button  |
| <b>C</b>     | — | Compressor Contactor         | <b>RES</b>   | — | Resistor  |
| <b>CB</b>    | — | Circuit Breaker              | <b>SEC</b>   | — | Secondary   |
| <b>CGF</b>   | — | Circuit Ground Fault         | <b>SN</b>  | — | Sensor (Toroid)   |
| <b>CH</b>    | — | Crankcase Heater             | <b>T</b>   | — | Thermistor  |
| <b>CHC</b>   | — | Cooler Heater Cable          | <b>TB</b>  | — | Terminal Block  |
| <b>CHT</b>   | — | Cooler Heater Thermostat     | <b>TDR</b>   | — | Time Delay Relay  |
| <b>CO</b>    | — | Convenience Outlet           | <b>TEMP</b>  | — | Temperature   |
| <b>COMP</b>  | — | Compressor                   | <b>TRAN</b>  | — | Transformer   |
| <b>CONT</b>  | — | Control                      |  |   | Terminal Block Connection                                 |
| <b>CR</b>    | — | Control Relay                |  |   | Marked Terminal   |
| <b>CWFS</b>  | — | Chilled Water Flow Switch    |  |   | Unmarked Terminal   |
| <b>CWPI</b>  | — | Chilled Water Pump Interlock |  |   | Unmarked Splice   |
| <b>DGT</b>   | — | Discharge Gas Thermostat     |  |   | Marked Wire   |
| <b>DU</b>    | — | Dummy Terminal               |  |   | Marked Splice   |
| <b>EQUIP</b> | — | Equipment                    |  |   | Factory Wiring  |
| <b>EXV</b>   | — | Electronic Expansion Valve   |  |   | Field Control Wiring                                      |
| <b>FC</b>    | — | Fan Contactor                |  |   | Field Power Wiring  |
| <b>FCB</b>   | — | Fan Circuit Breaker          |  |   | Indicates Common Potential<br>(Does Not Represent Wiring) |
| <b>FM</b>    | — | Fan Motor                    |  |   |   |
| <b>FU</b>    | — | Fuse                         |  |   |   |
| <b>GND</b>   | — | Ground                       |  |   |   |
| <b>HPS</b>   | — | High Pressure Switch         |  |   |   |
| <b>HTR</b>   | — | Heater                       |  |   |   |
| <b>JB</b>    | — | Junction Box                 |  |   |   |
| <b>L</b>     | — | Light                        |  |   |   |
| <b>LCS</b>   | — | Loss of Charge Switch        |  |   |   |
| <b>OPS</b>   | — | Oil Pressure Switch          |  |   |   |
| <b>PL</b>    | — | Plug Assembly                |  |   |   |
| <b>PRI</b>   | — | Primary                      |  |   |   |
| <b>PWR</b>   | — | Power                        |  |   |   |

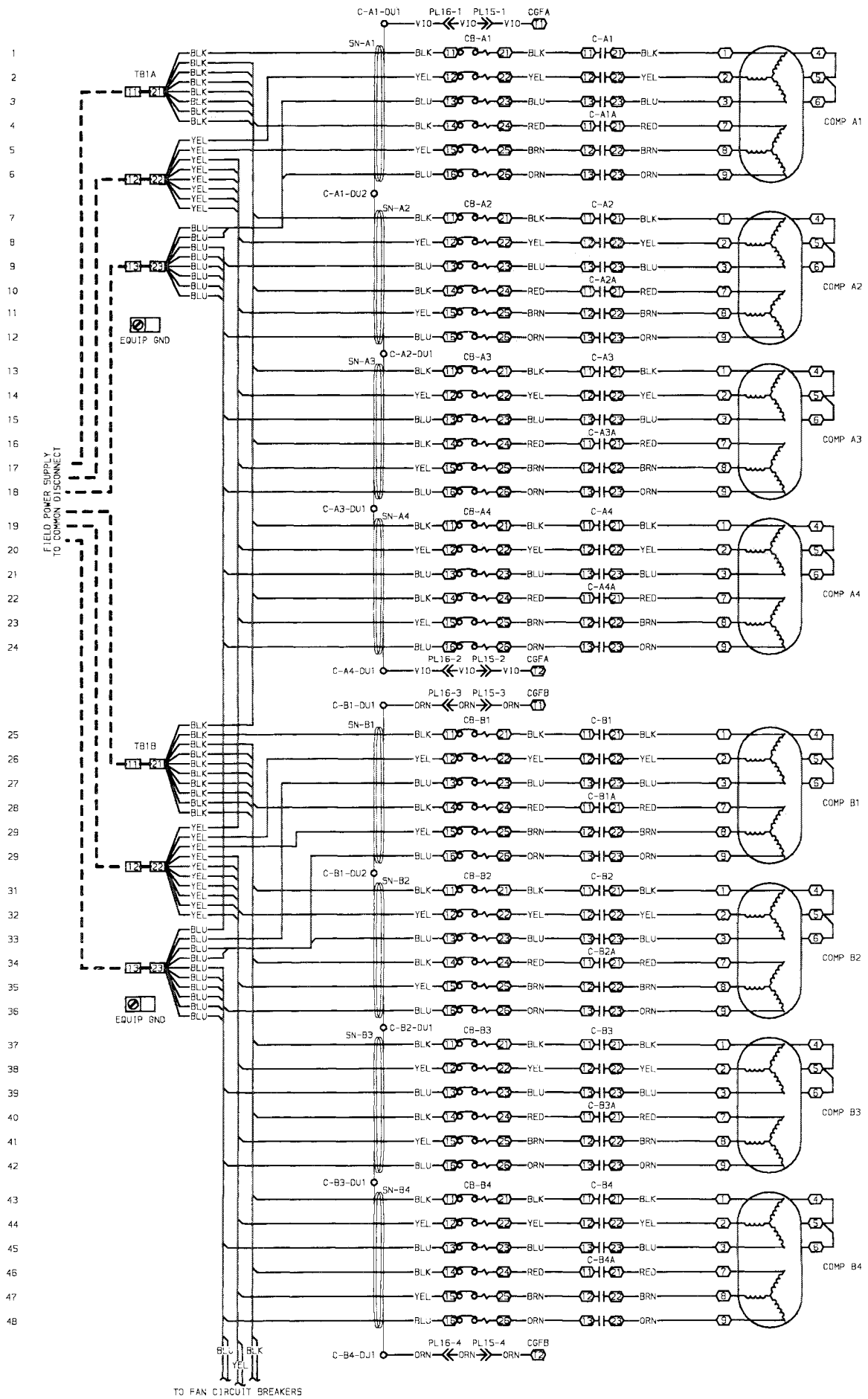

Fig. 1 – Compressor Power Schematic; 30GT225-280; 346, 380 Volts

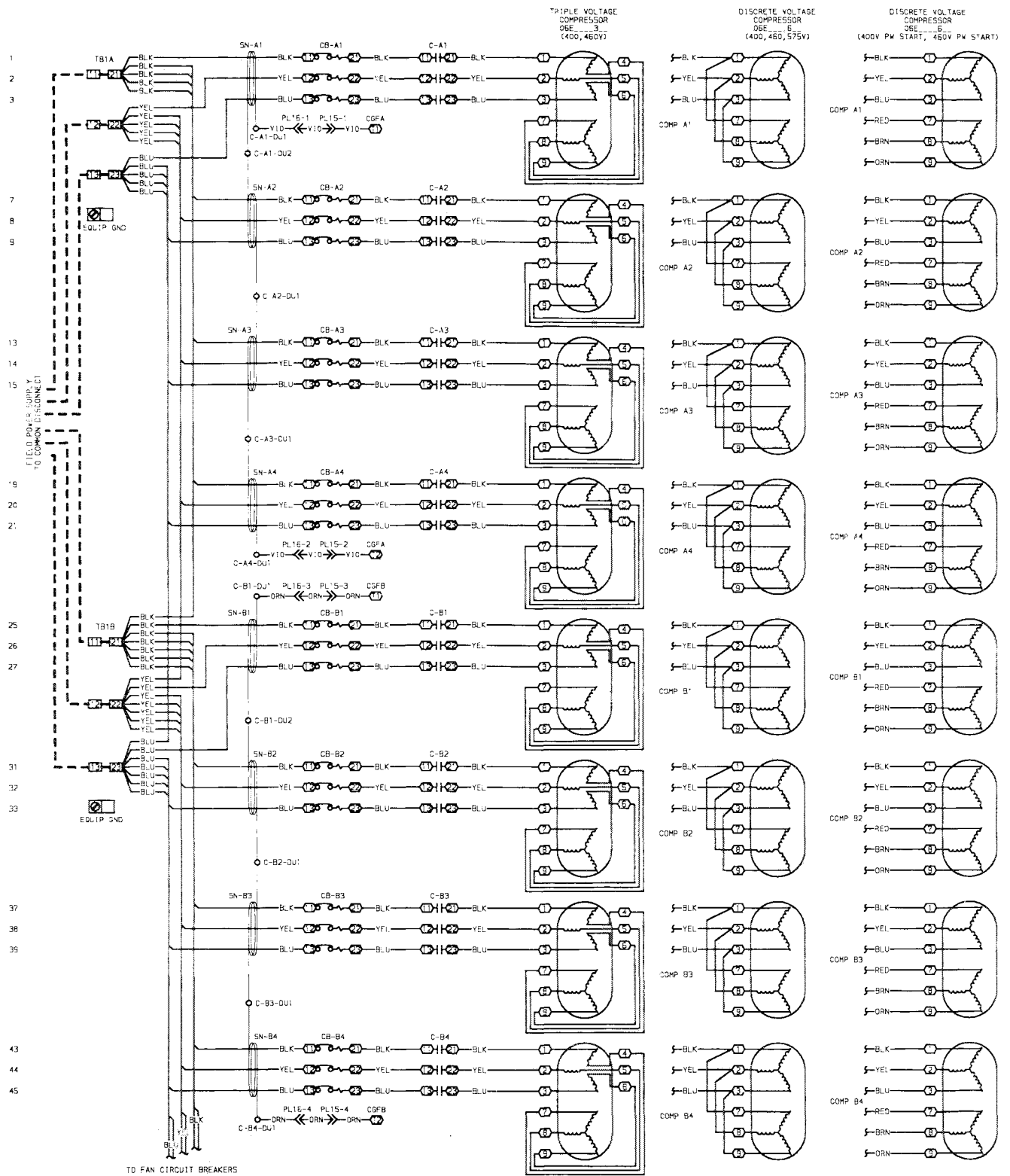
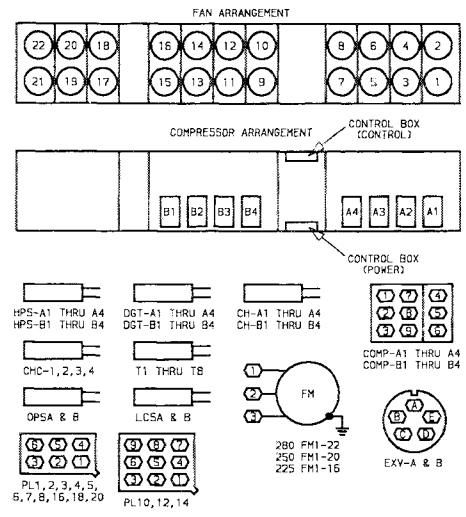
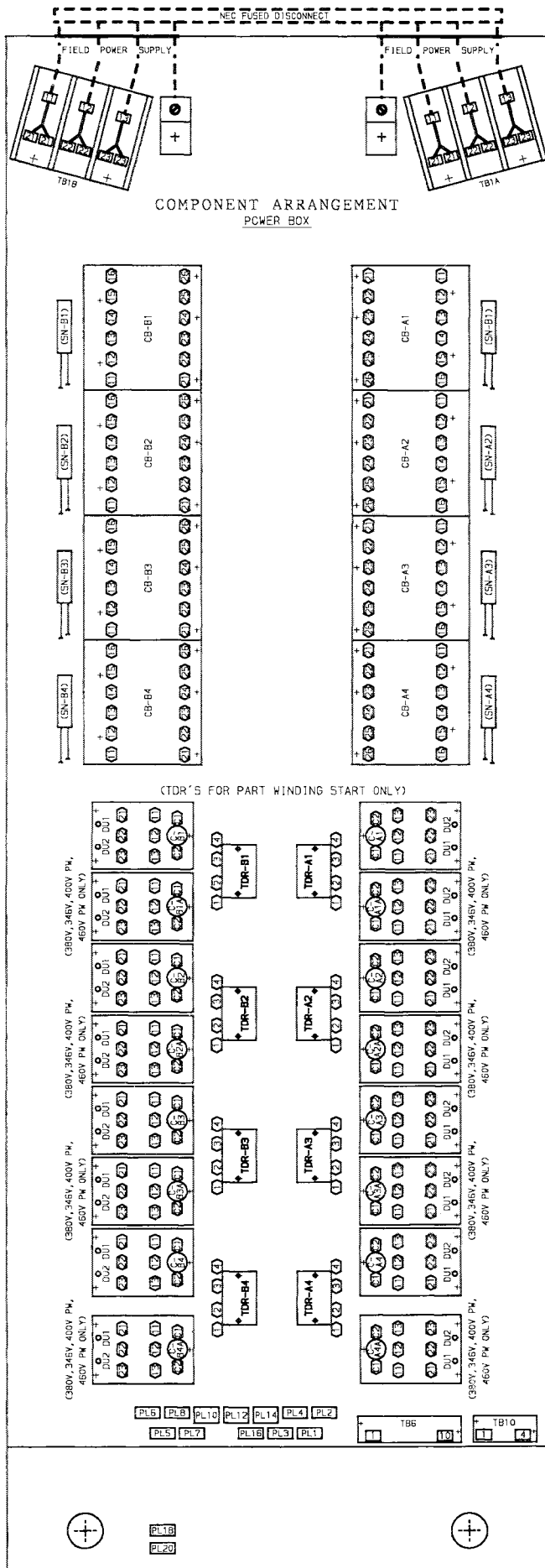

Fig. 2 – Compressor Power Schematic; 30GT225-280; 380/415, 460, 575 Volts



| UNIT SIZE  | VOL. TAGE | COMP #         | HEINEMANN  | COMP CB        | AIRPAX | MUST TRIP AMPS |
|------------|-----------|----------------|------------|----------------|--------|----------------|
| 30GT225600 | 460       | A1-A3, B1-B3   | CF3-233-25 | 219-3-2600-432 | 73     |                |
|            |           | A4, B4         | CF3-233-4  | 219-3-2600-405 | 102    |                |
| 30GT225600 | 460       | A1-A3, B1-B3   | CF6-23-26  | 219-6-2601-670 | 38     |                |
|            |           | A4, B4         | CF6-23-27  | 219-6-2601-671 | 53     |                |
| 30GT225100 | 575       | A1-A3, B1-B3   | CF3-233-23 | 219-3-2600-424 | 63     |                |
|            |           | A4, B4         | CF3-233-30 | 219-3-2600-434 | 82     |                |
| 30GT225200 | 380       | A1-A3, B1-B3   | CF6-23-14  | 219-6-2601-656 | 42     |                |
|            |           | A4, B4         | CF6-23-24  | 219-6-2601-668 | 52     |                |
| 30GT225900 | 400       | A1             | CF3-233-25 | 219-3-2600-432 | 73     |                |
|            |           | A2-A4, B1-B4   | CF3-233-4  | 219-3-2600-405 | 102    |                |
| 30GT225900 | 400       | A1             | CF6-23-26  | 219-6-2601-670 | 38     |                |
|            |           | A2-A4, B1-B4   | CF6-23-27  | 219-6-2601-671 | 53     |                |
| 30GT225300 | 346       | A1             | CF6-23-4   | 219-6-2601-612 | 44     |                |
|            |           | A2-A4, B1-B4   | CF6-23-25  | 219-6-2601-669 | 60     |                |
| 30GT250600 | 460       | A1, A2, B1, B2 | CF3-231-25 | 219-3-2600-432 | 73     |                |
|            |           | A3, A4, B3, B4 | CF3-233-4  | 219-3-2600-405 | 102    |                |
| 30GT250600 | 460       | A1, A2, B1, B2 | CF6-23-26  | 219-6-2601-670 | 38     |                |
|            |           | A3, A4, B3, B4 | CF6-23-27  | 219-6-2601-671 | 53     |                |
| 30GT250100 | 575       | A1, A2, B1, B2 | CF3-233-23 | 219-3-2600-424 | 63     |                |
|            |           | A3, A4, B3, B4 | CF3-233-30 | 219-3-2600-434 | 82     |                |
| 30GT250200 | 380       | A1, A2, B1, B2 | CF6-23-14  | 219-6-2601-656 | 42     |                |
|            |           | A3, A4, B3, B4 | CF6-23-24  | 219-6-2601-668 | 52     |                |
| 30GT250900 | 400       | ALL            | CF3-233-4  | 219-3-2600-405 | 102    |                |
|            |           | ALL            | CF6-23-27  | 219-6-2601-671 | 53     |                |
| 30GT250300 | 346       | ALL            | CF6-23-25  | 219-6-2601-669 | 60     |                |
|            |           | ALL            | CF3-233-4  | 219-3-2600-405 | 102    |                |
| 30GT280600 | 460       | ALL            | CF6-23-27  | 219-6-2601-671 | 53     |                |
|            |           | ALL            | CF3-233-30 | 219-3-2600-434 | 82     |                |
| 30GT280200 | 380       | ALL            | CF6-23-24  | 219-6-2601-668 | 62     |                |
|            |           | ALL            | CF6-23-24  | 219-6-2601-668 | 62     |                |

MOTOR-COMPRESSOR THERMALLY PROTECTED SYSTEM.  
CB MUST TRIP AMPS ARE LESS THAN OR EQUAL TO 156X RLA.

Fig. 3 - Component Arrangement, Power; 30GT225-280; All Voltages

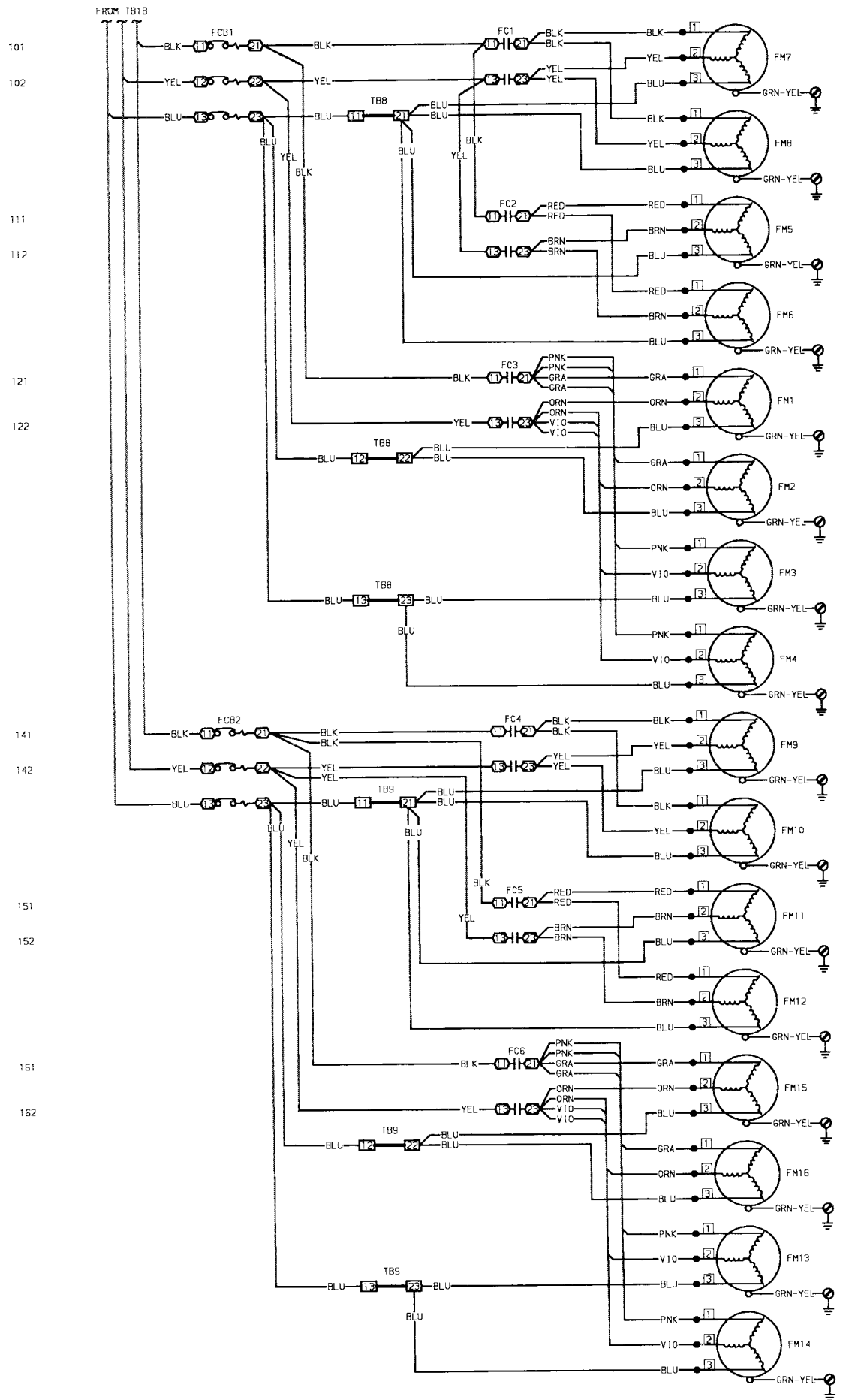

Fig. 4 – Fan Power Schematic; 30GT225

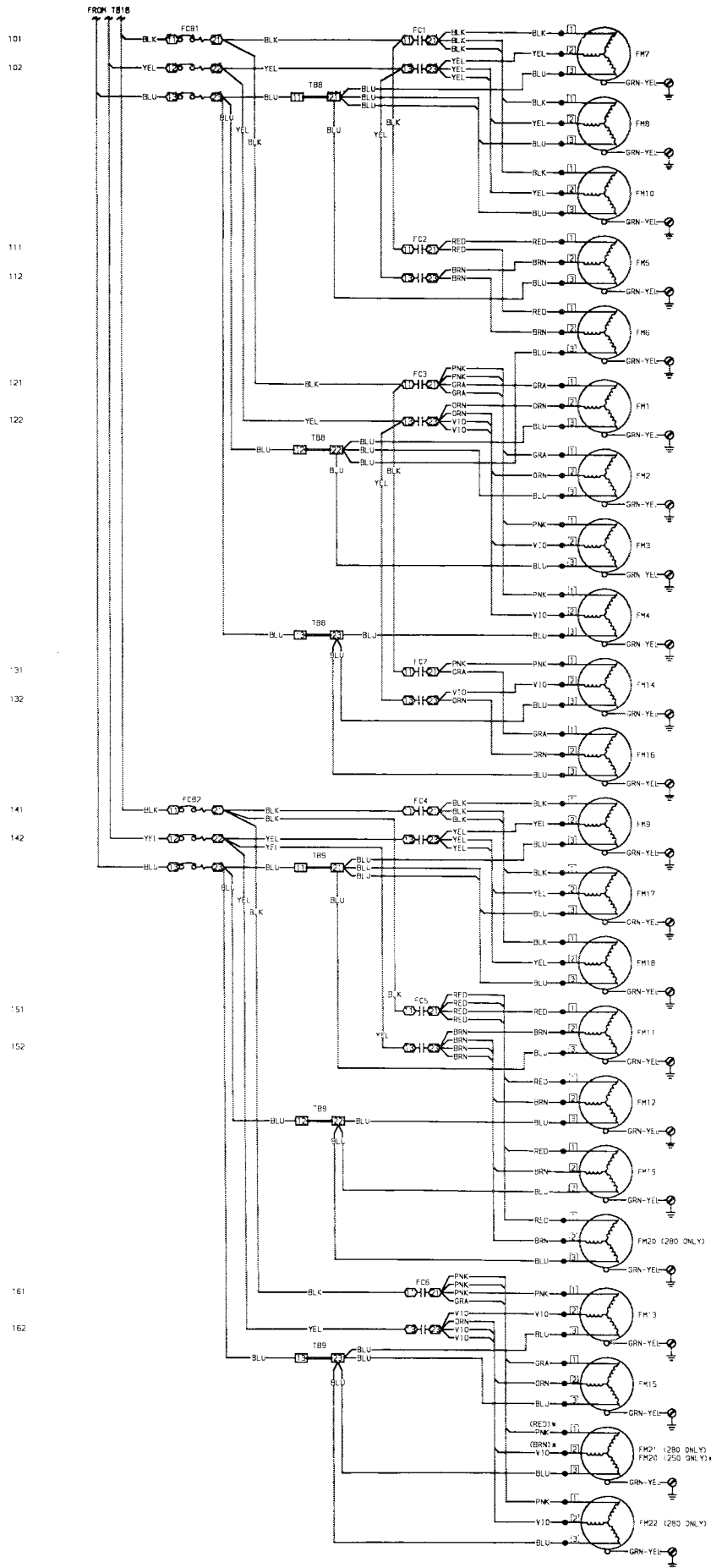

Fig. 5 - Fan Power Schematic; 30GT250, 280

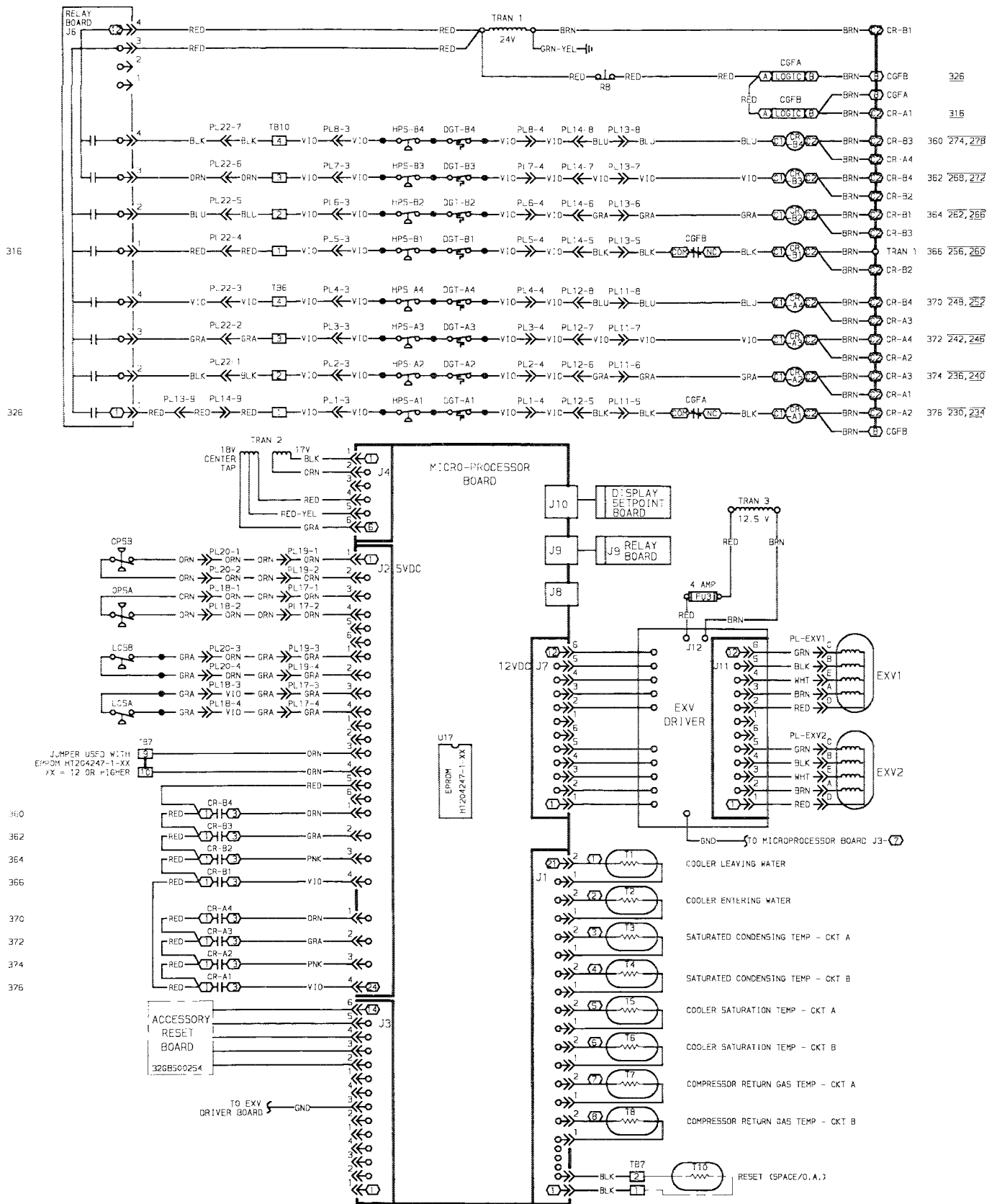

Fig. 6 – Control Power Schematic; 30GT225-280; 24 Volts

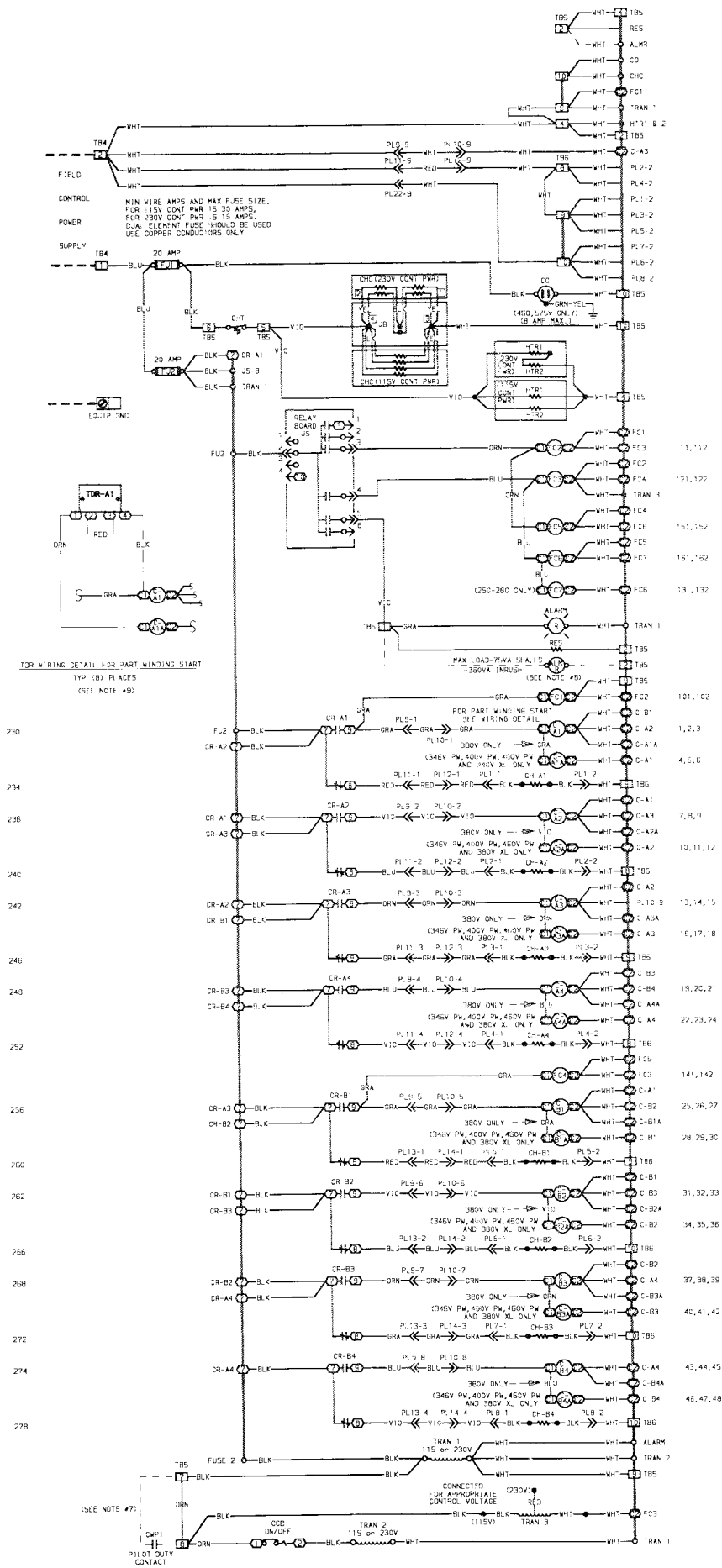
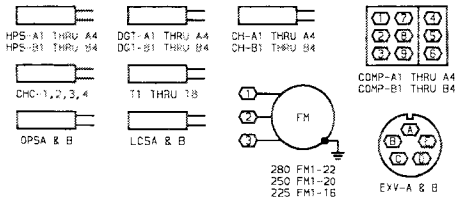
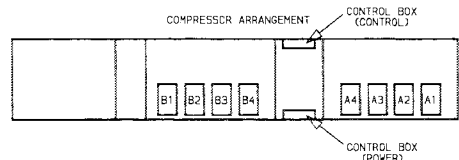
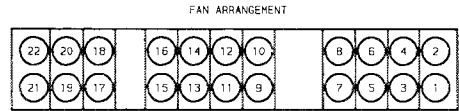
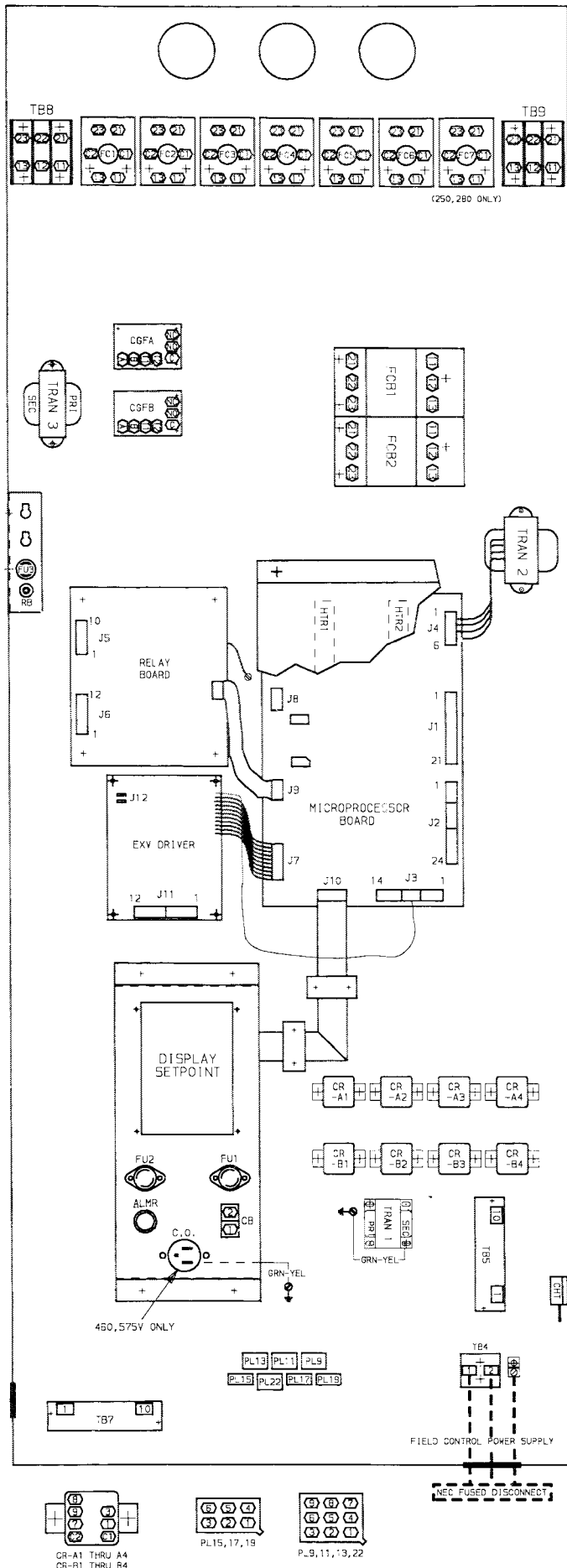

Fig. 7 – Control Power Schematic; 30GT225-280; 115, 230 Volts



| UNIT SIZE  | VOLTAGE | HEINEMANN  | AIRPAX         | MUST TRIP<br>AMPS |
|------------|---------|------------|----------------|-------------------|
| 30GT225800 | 450     | CF3-233-11 | 219-3-2600-412 | 37                |
| 30GT225100 | 575     | CF3-233-11 | 219-3-2600-412 | 37                |
| 30GT225200 | 380     | CF3-233-33 | 219-3-2600-437 | 50                |
| 30GT225900 | 400     | CF3-233-33 | 219-3-2600-437 | 50                |
| 30GT225300 | 346     | CF3-233-33 | 219-3-2600-437 | 50                |
| 30GT250600 | 450     | CF3-233-33 | 219-3-2600-437 | 50                |
| 30GT250100 | 575     | CF3-233-33 | 219-3-2600-437 | 50                |
| 30GT250200 | 380     | CF3-233-2  | 219-3-2600-403 | 71                |
| 30GT250400 | 400     | CF3-233-2  | 219-3-2600-403 | 71                |
| 30GT250300 | 346     | CF3-233-2  | 219-3-2600-403 | 71                |
| 30GT280600 | 450     | CF3-233-33 | 219-3-2600-437 | 50                |
| 30GT280100 | 575     | CF3-233-33 | 219-3-2600-437 | 50                |
| 30GT280200 | 380     | CF3-233-2  | 219-3-2600-403 | 71                |

MOTOR-COMPRESSOR THERMALLY PROTECTED SYSTEM.  
CB MUST TRIP AMPS ARE LESS THAN OR EQUAL TO 156% RLA.

Fig. 8 – Component Arrangement, Control; 30GT225-280; All Voltages

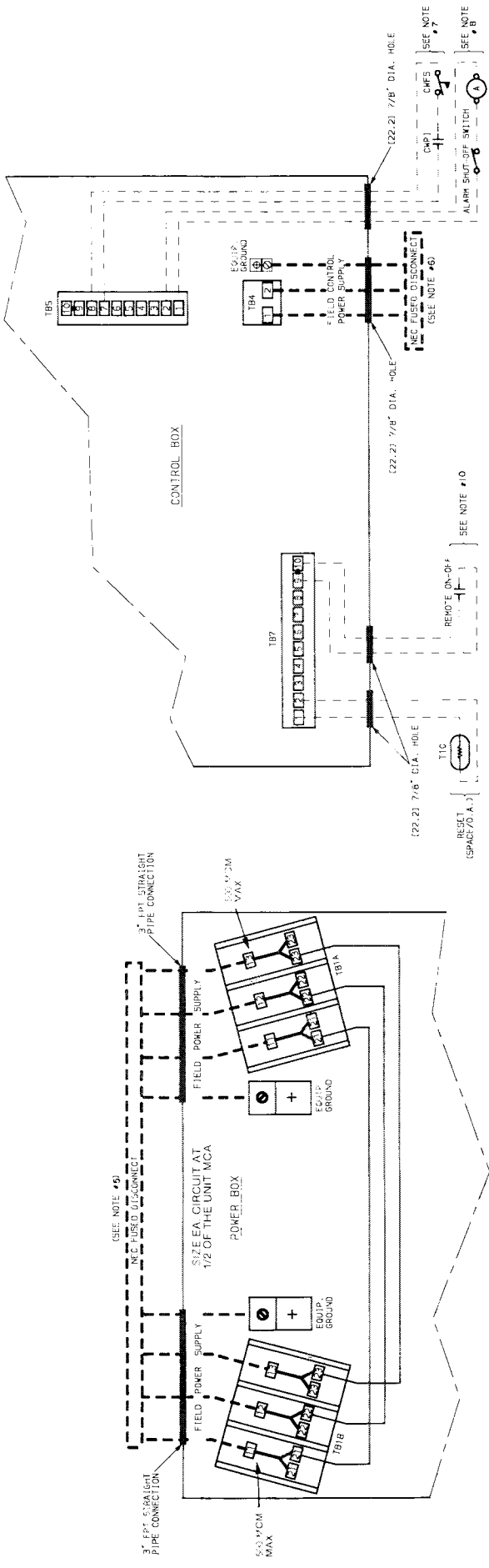

POWER CONDUCTORS (75 C MINIMUM)

| UNIT<br>30GT | VOLTS-<br>PH-HZ | COPPER,<br>ALUMINUM OR<br>COPPER CLAD<br>ALUMINUM<br>ALLOWED | COPPER<br>REQUIRED |
|--------------|-----------------|--|--------------------|
| 225          | 380-3-60        | ✓  |                    |
|              | 460-3-60        | ✓  |                    |
|              | 575-3-60        | ✓  |                    |
| 250          | 380-3-60        | ✓  |                    |
|              | 460-3-60        | ✓  |                    |
|              | 575-3-60        | ✓  |                    |
| 280          | 380-3-60        | ✓ (XL)   |                    |
|              | 460-3-60        | ✓  | ✓ (PW)             |
|              | 575-3-60        | ✓  | ✓                  |
| 225          | 346-3-50        | ✓  | ✓                  |
|              | 380/415-3-50    | ✓  | ✓                  |
| 250          | 346-3-50        | ✓  | ✓                  |
|              | 380-415-3-50    | ✓  | ✓                  |

PW -- Part Winding    XL -- Across the Line

Fig. 9 -- Field Wiring; 30GT225-280; All Voltages

**Field-Installed Accessories** — Ordering numbers for field-installed accessories are listed on 30GT225-280 price pages. For field installation of these accessories, see the installation instructions supplied with the accessories, or the Controls and Troubleshooting Guide supplied with the unit, in addition to the following instructions. Refer to the wiring labels for complete unit wiring schematics and location of control box components.

**DEMAND LIMIT CONTROL MODULE (DLCM)** — For a more detailed description of installation, see separate installation instructions supplied with the accessory.

**Demand Limit Control Module Usage**

| POWER TO DLCM | CARRIER PART NO. |
|---------------|------------------|
| 115-1-60      | 32GB400274       |
| 230-1-50/60   | 32GB400284       |

Installation

**▲ CAUTION**  
Before proceeding, shut off all power to unit.

1. Open control box doors and remove the sheet metal cover over the processor board.
2. Remove plastic cover over the dip switches and set switch no. 5 to the ON position. Replace plastic cover.
3. Mount the DLCM circuit board in the control box.
4. Attach the connector at the end of the DLCM wires to terminals 1, 2, 3 on connector J3 on the processor board. See Fig. 10.

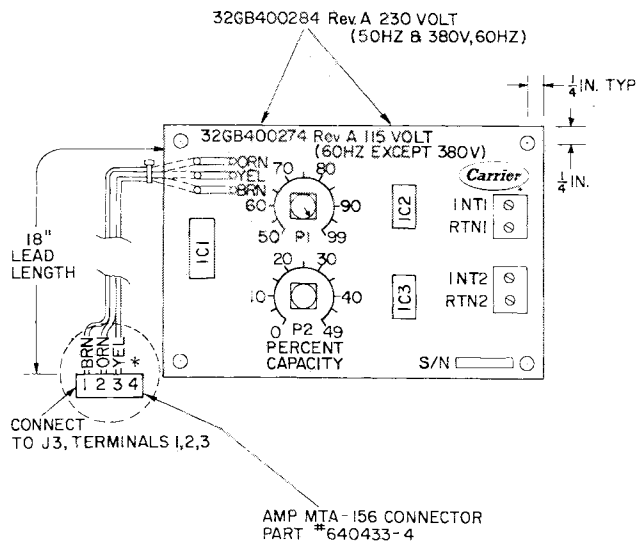

\*Connector wiring must be as shown for Rev. A.

**Fig. 10 — Demand Limit Control Module**

5. Connect the field input control power wires to the terminal strips marked INT1, RTN1 and INT2, RTN2 which are pressure type connectors; strip the insulation from the wires before inserting. The connector can take up to 12 AWG wire. See Fig. 11.

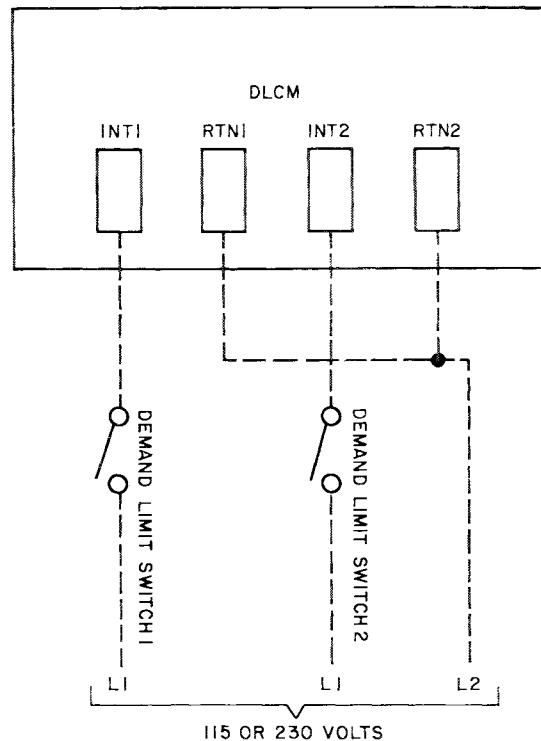

**Fig. 11 — DLCM Electrical Connections**

6. Set the potentiometers to the desired capacity limit.
7. Check the operation, using the Quick Test procedure described in unit Installation Instructions or the Controls and Troubleshooting booklet.

**TEMPERATURE RESET BOARD** — This accessory permits adjustment of leaving chilled water temperature based on return water, space or outdoor temperature. For a more detailed description of return temperature reset installation, see the Controls and Troubleshooting Guide (return temperature reset) supplied with the unit. Part no. is 30GB500254.

Installation (Based on return water temperature reset)

1. Turn off all power to the chiller.
2. Open the control box doors and remove the sheet metal cover over the processor board.
3. Remove the accessory temperature reset board from its packaging and install it in the unit. The board should be mounted on the panel adjacent to J3 on the processor board as shown in Fig. 12.
4. The board is equipped with a 15-in. (381-mm) long wire harness and connector. Route the wires down along the side of the processor board as shown in Fig. 12.

5. Remove the cover from the dip switch assembly and set dip switches 1 and 2 to the ON position.
6. Determine the settings of the reset ratio, reset limit and cold set point potentiometer as defined in the return temperature reset operating instructions in the Controls and Troubleshooting Guide.
7. Use the Quick Test to verify that dip switches 1 and 2 are set properly and that the cold set point, reset ratio and reset limit potentiometers are working properly (see Controls and Troubleshooting Guide).
8. Replace the plastic cover over the dip switches and re-install the sheet metal cover over the board.
9. Close the control box covers and start the unit to confirm that the unit operates properly.

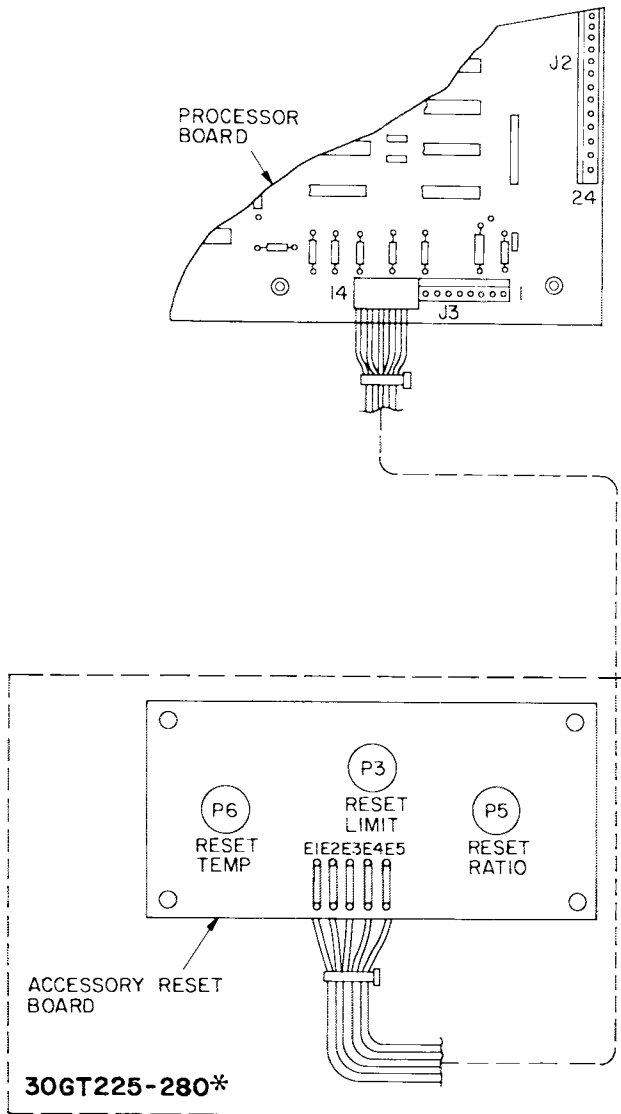

**SENSOR KIT ASSEMBLY** (used with temperature reset board for space and outside air temperature reset of the leaving chilled water temperature) — For a more detailed description of installation, see Controls and Troubleshooting Guide (space and outside air temperature reset) supplied with the unit. Sensor kit part no. is 30GB660002.

Installation

1. Turn off all power to the chiller.
2. Open the control box doors and remove the sheet metal cover over the processor board.
3. Remove the accessory temperature reset board from its packaging and install it in the unit. The board should be mounted on the panel adjacent to J3 on the processor board as shown in Fig. 12.
4. The board is equipped with a 15-in. (381-mm) long wire harness and connector. Route the wires down along the side of the processor board and connect to the connector J3 on the processor board as shown in Fig. 12.
5. Remove the cover from the dip switch assembly and set dip switch 1 to the OFF position and 2 to the ON position.
6. Remove reset thermistor from its packaging for installation. See Fig. 13. The thermistor should be connected to the terminal block as shown in Fig. 14. To avoid electrical interference DO NOT run the thermistor wire near line voltage wiring, electrical machinery, large contactors or other devices. Wire lengths up to 1000 ft (304 m) may be used with 22-gage wire.

The accessory thermistor is equipped with 30 ft (9.1 m) of 22-gage twisted-pair cable. If additional length is required, use twisted-pair wire with a minimum of one twist per inch. The additional wire should be spliced onto the end of the 30-ft (9.1-m) wire. All connections should be soldered.

When outside air reset is used, the thermistor should be mounted in a location that is shielded from the sun.

When using space reset, the thermistor should be mounted in an area within the space where it senses freely circulating air.

\*See component arrangement label for exact location.  
 NOTE: Connector and 15-in. wire are preinstalled on the accessory board. Connect to terminal strip J3 on the processor board. Terminals 9 through 14 should be used on the processor board. Location 9 does not have a pin and is used for polarization.

**Fig. 12 — Temperature Reset Board, Location and Wiring**

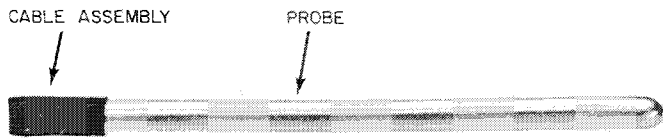

Fig. 13 - Reset Thermistor

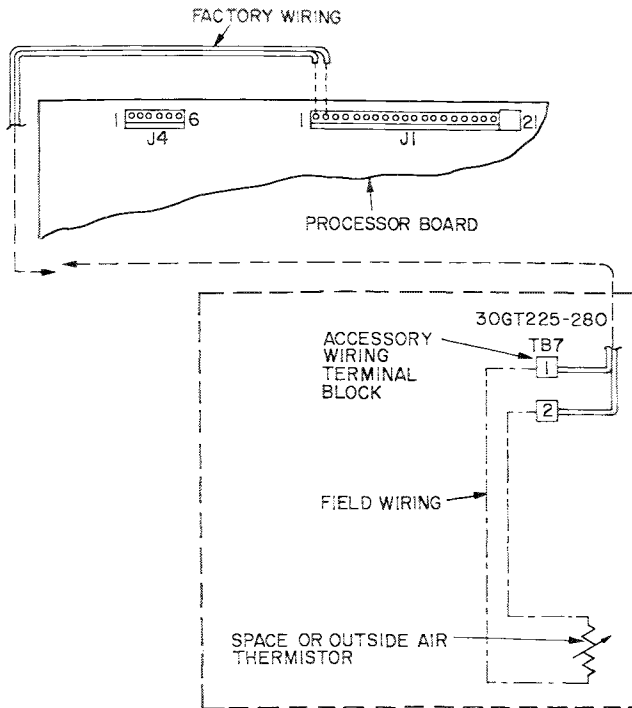

Fig. 14 - Space/Outside Air Thermistor Connections

7. Determine the settings of the reset ratio, reset limit, reset set point and cold set point as defined in the space and outside air reset operating instructions (see Controls and Troubleshooting Guide).
8. Use the Quick Test to verify that dip switches 1 and 2 are set properly and that the cold set point, reset ratio, reset limit, and reset point are set properly (see Controls and Troubleshooting Guide).
9. Replace the plastic cover over the dip switches and re-install the sheet metal cover over the board.

10. Close the control box covers and start the unit to make sure it operates properly.

**REMOTE ON-OFF CONTROL** — If remote ON-OFF unit control is required, a field-supplied relay (part no. HN61KK025) must be installed in unit control box and wired as shown in Fig. 15. Remote switch contacts are field supplied.

**NOTE:** Units produced prior to April 1987 (S/N Q7 - - - -) require software (EPROM) change in order to use remote ON-OFF function.

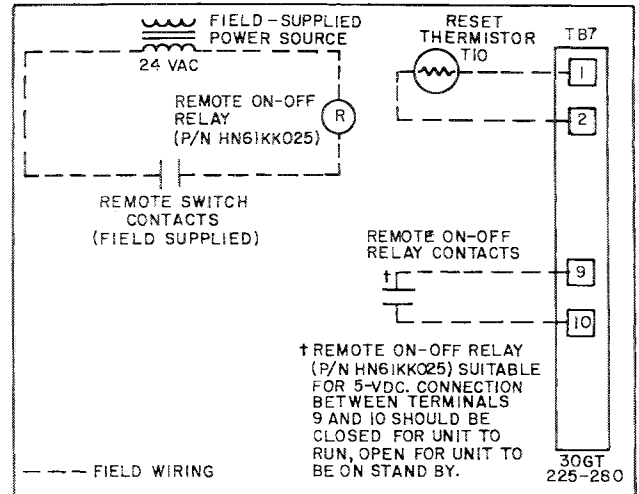

Fig. 15 - Remote On/Off Control

**REMOTE ALARM** — The unit is equipped with a master alarm circuit that is energized any time that a diagnostic code of **51** to **87** is displayed. It is also energized during the Quick Test. The alarm circuit is powered by a 115- or 230-v relay depending on unit. The relay is located on the relay board. The same relay is used to energize the alarm light.

To install a remote alarm light or other device, it can be connected to TB5 terminals 1 and 2 (see Fig. 16). A resis-

tor is installed across these same terminals to provide a minimum current draw through the contacts of the relay board. When an external alarm is not installed, remove this resistor. The maximum load that the relay can handle is 75 va sealed, 360 va inrush at 115 and 230 volts.

If a load with a greater va is to be used, an interface pilot duty relay must be used.

If a remote audible alarm is used, it is recommended that a remote alarm-off switch be installed.

**EXTERNAL INTERLOCKS** —The unit is equipped with provisions for external interlock devices such as pump starter,

and chilled water flow switch. See Fig. 16. On units 30GT225-280, an orange jumper connects terminals 7 and 8 on terminal board TB5.

Remove the jumper and install remote interlock contacts across terminals. Several devices can be connected in series.

**⚠ CAUTION**  
Do not use the pump starter as a remote ON-OFF switch.

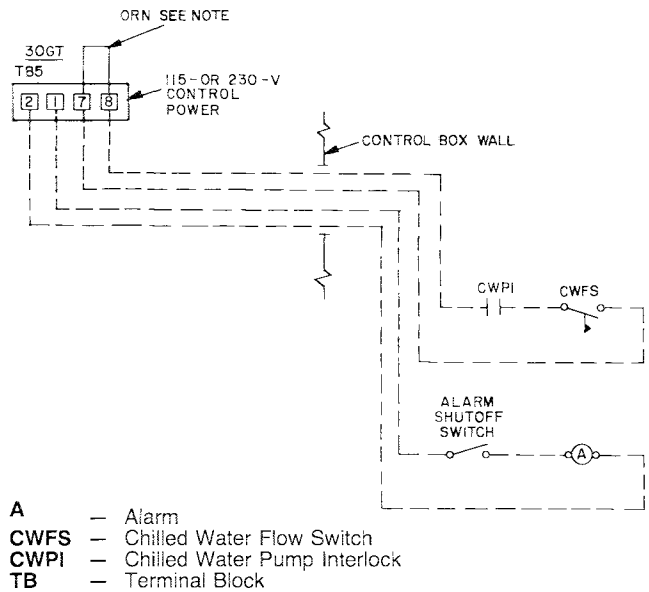

NOTE: Remove ORN jumper between terminals 7 and 8 on TB5 (30GT225-280) when installing interlocks.

**Fig. 16 — External Interlocks and Alarm**